

Series 20
High Performance Butterfly Valve

Contents

SN	Description	Page
1	Foreword	3
2	Model Numbering	3
3	Engineering Data	4
4	Features and Benefits	5
5	Types of Seal	6
6	Part List Description	7
7	Material of Construction	8
8	Flow Coefficients	9
9	Valve Torque	11
10	Break Torque	12
11	Dimensions & Weights	14
12	End Connection Bolting Details (LW)	17
13	End Connection Bolting Details (DF)	18

Foreword

FCC Butterfly Valve design eliminates rubbing action of the sealing elements during the entire 90-degree rotation. Direct line contact between the seal and disc seating surface is established only when closed position is reached.

Model Numbering

Series	Rating	Trim Type	Temperature
20	1- 150	10- Double Offset, Soft Seal	1- Warm Service
	2- 300	20- Double Offset, Metal Seal	2- Cryogenic
	3- 600	2X- Double Offset, Fire Safe Seal	

Engineering Data

Body Style	Lugged Wafer, Double Flanged Short
Design	API 609, ASME B16.34, IS 13095
Sizes, Pressure rating	3" to 36", ASME Class 150-600, IS 13095 (PN 2.5 – 4)
Trim Type	Double Offset
Flow Characteristics	Modified Equal Percentage (Inherent)
Seat Leakage	ANSI / FCI 70.2 / IEC 60534-4 Standard: Class IV - Class VI Optional: API 598
Flow Direction	Flow to Close (Standard) Bi-Directional on Request
NACE Conformance	NACE Conformance shall be Offered for Body and Disc material when required
Seal Style	Metal Seal Soft Seal (PTFE Based) Fire Safe Seal
End Connection Styles	Standard Flanged RF as per ASME B16.5 Optional Flanged FF as per ASME B16.5
Face To Face	API 609

Features and Benefits

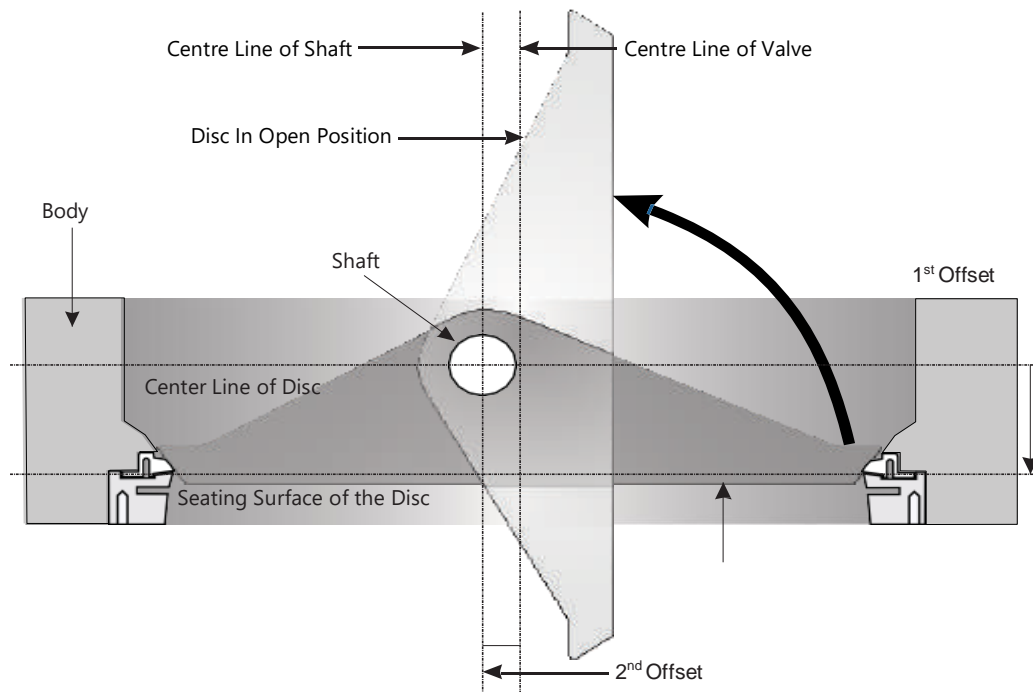

First Offset

The rotation axis of the disc/shaft is moved back from the seating surfaces of the disc. The purpose of this offset is to have a continuous sealing surface on the disc. It allows replacement of seal without removing the disc

Second Offset

This is achieved by placing the shaft offset to one side of the valve centre line. The purpose of this offset is to drive away the disc from the seat more quickly as it moves. Thus, reducing friction and wear.

Types of Seal

Soft Seal

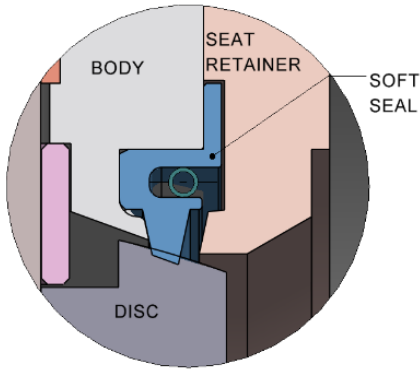

Applications requiring control over the flow of the pipeline and tight shut off on liquids or gases in the closed position are recommended to use soft seals.

Resilient seals, such as PTFE, glass-filled PTFE and EPDM etc., facilitate a clear flow passage and prevent fluid build-up inside of the seal. The temperature range for operation is -196°C to 232°C , based on the material

Metal Seal

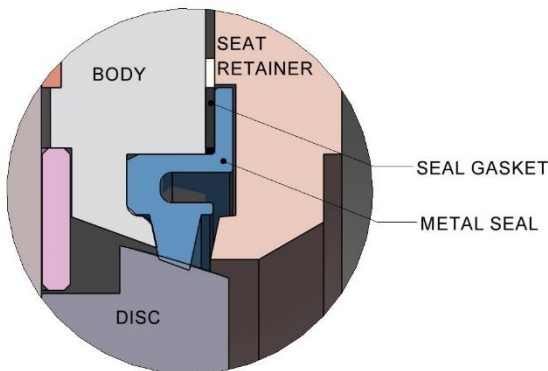

For applications demanding a Class IV shut-off in the closed position, especially in scenarios where elevated temperatures or arduous service conditions make the use of a soft seal impractical, a Flexible Metal seal is recommended.

The operating temperature range for this type of seal is from -196°C to 427°C . The choice of a Flexible Metal seal is driven by its ability to withstand harsh conditions and maintain a reliable shut-off, providing a robust solution where softer seals may not be suitable.

Fire Safe Seal

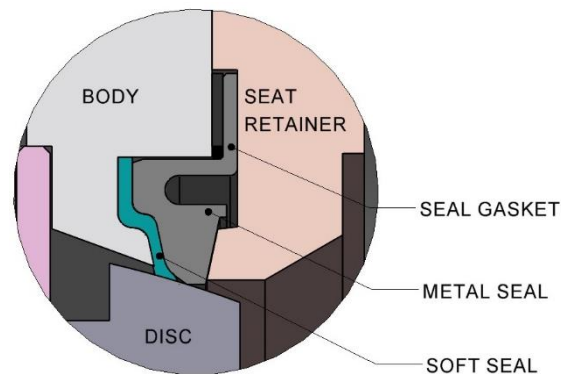

In applications requiring a dual-seal design for a 100% shut-off under normal operating conditions, a secondary metal seal functions as a backup in the event of a fire-induced deterioration of the soft seal. The metal seal safeguards the valve's integrity by allowing only minimal leakage when in the closed position.

As a result, the valve remains operational post-fire until it is considered safe to be removed for seal overhauling. This design ensures the sustained functionality and safety of the valve in conditions following a fire incident.

Part List Description

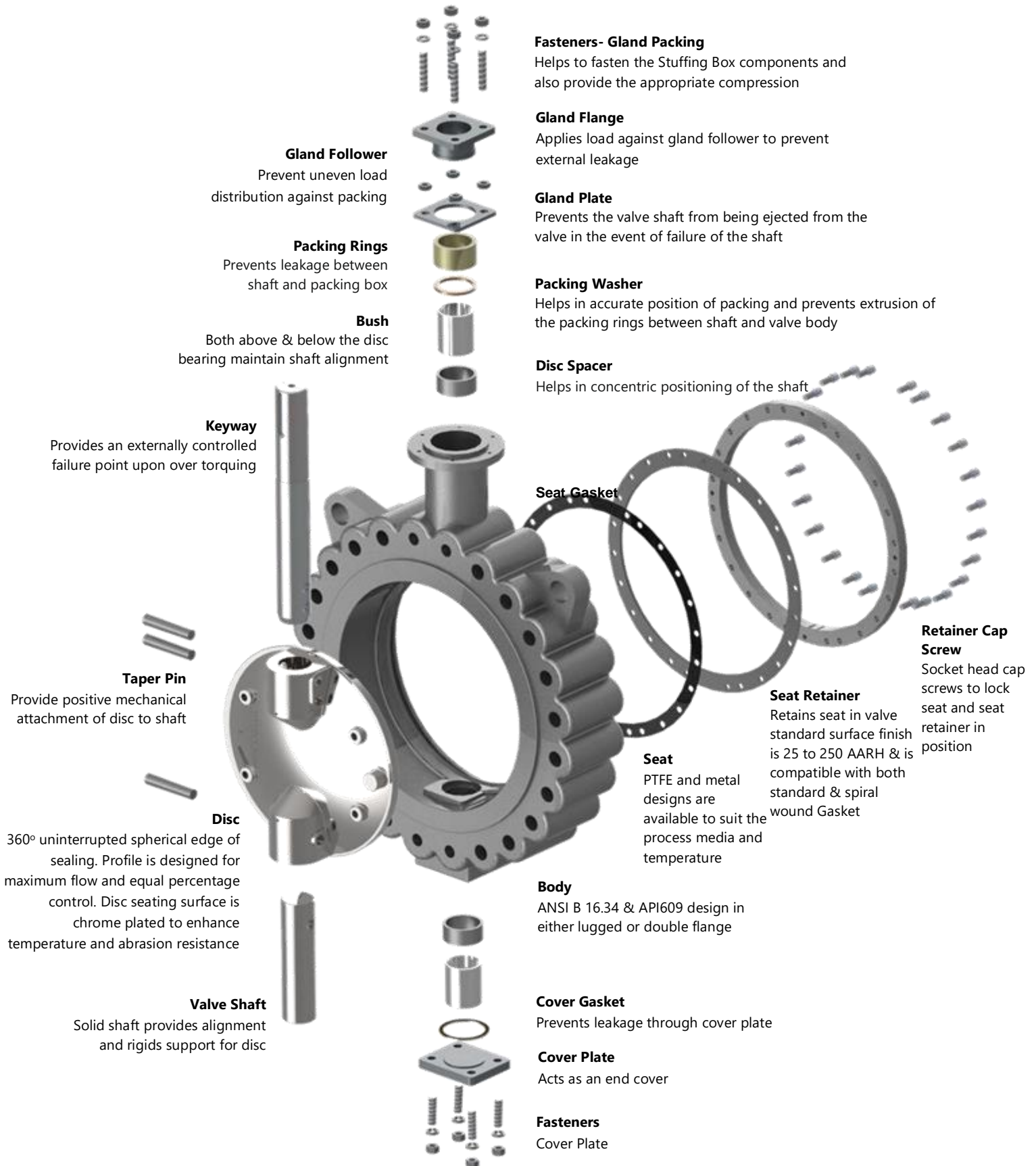

Material Of Construction

Key No.	Description	Carbon Steel	Stainless Steel	Duplex	Super Duplex	Al. Bronze	Monel
1.	Valve Body	WCB	CF8M	4A	6A	C95400	M35-1
2.	Disc	CF8M	CF8M	4A	6A	C95400	M35-1
3.	Drive shaft	17-4PH	17-4PH	S32760	S32760	Alloy K500	Alloy K 500
4.	Non-drive shaft	17-4PH	17-4PH	S32760	S32760	Alloy K500	Alloy K500
5.	Taper pin	17-4PH	17-4PH	Alloy 718	Alloy 718	Alloy 718	Alloy 718
6.	Seal Gasket	Graphite+ S31600		Graphite + Alloy 625			
7A	Body Metal Seal	S31600	S31600	S32760	S32760	Alloy 625	Alloy 625
7B	Body Soft Seal	PTFE					
8.	Seal Retainer	S31600	S31600	S32760	S32760	Alloy 625	Alloy 625
9.	Retainer Cap Screws	S31600	S31600	S32760	S32760	Alloy 625	Alloy 625
10.	Disc Spacer	XM-19	XM-19	S32760	S32760	Alloy 625	Alloy 625

Key No.	Description	Carbon steel
11.	Guide Bush	DU Bush
12.	Gland Flange	S31600
13.	Gland Follower	S31600
14.	Gland Plate	S31600
15.	Packing	PTFE
16.	Packing washer	Alloy 625
17.	Gland stud & nut	S31600
18.	Cover plate	S31600, S32760
19.	Cover Gasket	S31600 spiral wound graphite
20.	Cover stud & nut	S31600

Optional Variants

NACE MR-0175 / ISO 15156 & MR-0103 Conformance

Stellite on disc seating area

Alloy 718, XM-19 shaft based on valve torque

Stellite bush

Graphite packing

Alloy 625 Cover plate

Flow Coefficients

ASME Class 150

Valve Size (in)	Degree of opening			
	10	60	70	90
3	3	103	135	165
4	5	150	210	300
6	20	272	374	621
8	86	969	1340	1563
10	143	1660	2464	2915
12	207	2248	3518	4308
14	215	2868	4392	5659
16	309	3771	6087	7836
18	402	4553	7604	9860
20	492	5893	9854	13066
24	716	8215	14305	19780
30	1112	12940	24128	34880
36	1625	18680	32023	44371

Note: 1. Double offset Butterfly valve with standard disc

Note:2. Direction: Seat downstream flow

ASME Class 300

Valve Size (in)	Degree of opening			
	10	60	70	90
3	3	98	128	157
4	5	143	200	285
6	20	185	355	580
8	84	948	1323	1537
10	134	1538	2316	2840
12	201	2217	3270	4116
14	190	2666	3836	4952
16	256	3652	5492	7663
18	344	4298	6827	8576
20	485	5587	8333	10546
24	678	7894	12442	16166
30	1064	12593	20420	27852

Note: 1. Double offset Butterfly valve with standard disc

Note:2. Direction: Seat downstream flow

Series-20 High Performance Butterfly Valve

ASME Class 600

Valve Size (in)	Degree of opening			
	10	60	70	90
3	3	93	122	149
4	5	135	190	271
6	19	180	200	565
8	77	940	1305	1519
10	104	1342	1769	2011
12	172	2095	2790	3419
14	169	2356	3204	4197
16	222	3193	4137	4948
18	321	4322	5887	7370
20	459	5655	8194	10179
24	565	7886	12194	15790
30	1000	12506	19635	27419

Note: 1. Double offset Butterfly valve with standard disc

Note:2. Direction: Seat downstream flow

Valve Torque

Dynamic Torque

The Double Offset Geometry results in Torque that tends to rotate the disc towards the seat and assists valve closure, as the fluid flows in the preferred direction (seat down-stream)

Combined effect of Geometry and the Hydro dynamic fluid pressure around the disc, results in a torque that increases steadily with increase in opening and reaches its peak at around 70-80 degree and thereafter falls rapidly.

Neglect the dynamic torque values if used for ON/OFF applications.

Hydrodynamic torque characteristics is represented in **chart – 1** below

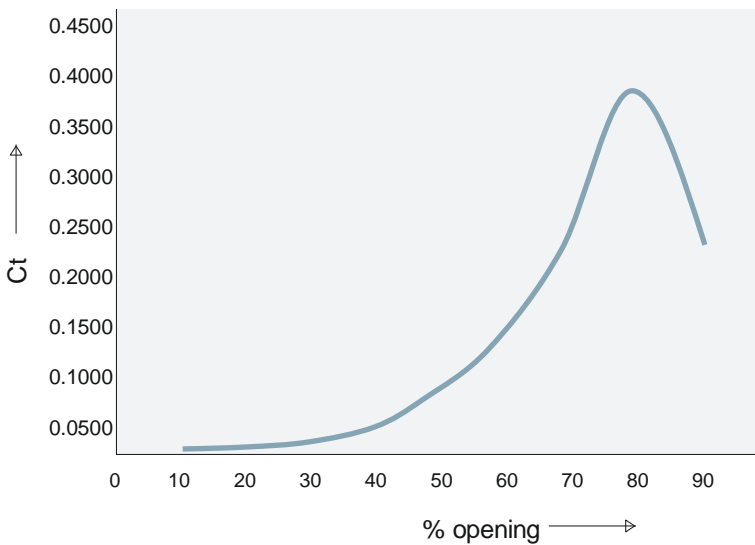

Chart-1: Ct Vs % opening

Table 4: Co-efficient of dynamic torque Ct

Percentage of Opening	Coefficient of dynamic torque
10	0.0036
20	0.0073
30	0.0226
40	0.0452
50	0.0839
60	0.1372
70	0.2292
80	0.376
90	0.2228

Hydrodynamic torque can be calculated using the formula

$$T_d = (C_t \times D) \times \Delta P$$

Where, T_d – Dynamic Torque in lbs inch

C_t – Torque Coefficient Factor

D – Disc Diameter in inch

ΔP – Pressure Drop in psi(g)

Break Torque

MAST – Maximum Allowable Shaft Torque. 17-4 PH is the standard shaft material

The MAST value corresponds to 17-4 PH, For other materials multiply this value with the factors given in the table below.

Materials	Nitronic 50	S32760	Monel K500	Inconel 718
Factor	0.7	0.82	0.97	1.9

Under certain conditions, hydrodynamic torque can meet or exceed the Break Torques.

When designing valve systems, hydrodynamic torque must be considered to ensure correct selection of actuator.

Break Torque – ASME Class 150

Conversion: 1 lbs.inch =0.1129Nm

Size (inch)	Stem Dia (inch)	Soft Seal (lbs.in)				Fire Safe seal(lbs.in)				Metal Seal (lbs.in)				MAST (lbs.in) lbs.in
		Differential Pressure (bar)				Differential Pressure (bar)				Differential Pressure (bar)				
		5	10	15	20	5	10	15	20	5	10	15	20	
3	0.675	461	533	605	677	524	596	668	739	712	784	855	927	2903
4	0.75	588	720	852	984	661	792	924	1056	878	1010	1141	1273	5016
6	0.75	926	1243	1561	1878	1036	1354	1671	1989	1368	1685	2002	2320	5016
8	1	1687	2352	3017	3682	1887	2552	3217	3882	2487	3152	3817	4481	11889
10	1	2426	3426	4426	5426	2727	3727	4727	5727	3629	4629	5629	6629	11889
12	1.25	3752	5439	7126	8813	4200	5886	7573	9260	5540	7227	8914	10600	23221
14	1.5	5207	7710	10213	12715	5800	8302	10805	13308	7578	10080	12583	15086	40126
16	1.5	6808	10133	13458	16783	7595	10920	14246	17571	9957	13282	16608	19933	40126
18	1.75	9100	13794	18488	23181	10105	14798	19492	24186	13118	17812	22505	27199	63718
20	2	11543	17776	24008	30240	12760	18992	25224	31456	16410	22642	28874	35106	95113
24	2.25	17534	27449	37365	47280	19314	29229	39144	49060	24653	34568	44483	54398	135425
30	3	32461	52610	72759	92907	35374	55522	75670	95819	44109	64257	84405	104554	321007
36	3.25	47376	78204	109032	139859	51320	82146	112974	143802	63148	93975	124803	155630	509748

Series-20 High Performance Butterfly Valve

Break Torque – ASME Class 300

Conversion: 1 lbs.inch =0.1129Nm

Size (inch)	Stem Dia (inch)	Soft Seal (lbs.in)				Fire Safe seal(lbs.in)				Metal Seal (lbs.in)				MAST (lbs.in)
		Differential Pressure (bar)				Differential Pressure (bar)				Differential Pressure (bar)				
		20	30	40	50	20	30	40	50	20	30	40	50	
3	0.625	738	912	1086	1260	800	974	1148	1322	988	1162	1336	1510	2903
4	0.75	963	1216	1469	1722	1035	1288	1541	1794	1252	1505	1759	2012	5016
6	1	1961	2609	3257	3905	2071	2719	3367	4016	2402	3050	3699	4347	11889
8	1.25	3766	5109	6453	7797	3966	5309	6653	7997	4565	5909	7253	8597	23221
10	1.25	5537	7565	9594	11622	5838	7866	9894	11922	6741	8769	10797	12825	23221
12	1.5	8932	12338	15743	19149	9379	12785	16190	19595	10720	14125	17531	20936	40126
14	2	13157	18328	23499	28669	13750	18920	24091	29262	15528	20698	25869	31040	95113
16	2	16696	23246	29797	36348	17483	24033	30584	37135	19845	26395	32946	39497	95113
18	2.25	23427	32882	42336	51791	24432	33886	43341	52795	27445	36899	46354	55809	135425
20	2.75	30835	43513	56192	68870	32052	44730	57409	70087	35702	48380	61059	73737	247257
24	3	48681	69128	89576	110024	50461	70907	91356	111803	55800	76246	96695	117142	321007
30	3.5	94743	135900	177060	218218	97654	138811	179971	221129	106389	147546	188706	229865	509748

Break Torque – ASME Class 600

Conversion: 1 lbs.inch =0.1129Nm

Size (inch)	Stem Dia (inch)	Soft Seal (lbs.in)				Fire Safe seal(lbs.in)				Metal Seal (lbs.in)				MAST (lbs.in)
		Differential Pressure (bar)				Differential Pressure (bar)				Differential Pressure (bar)				
		50	65	80	100	50	65	80	100	50	65	80	100	
3	0.625	1260	1521	1782	2130	1405	1691	1977	2358	1593	1879	2164	2546	2903
4	0.75	1722	2102	2481	2988	1934	2356	2778	3340	2152	2573	2995	3557	5016
6	1	3905	4878	5850	7146	4353	5426	6500	7931	4684	5757	6831	8262	11889
8	1.25	7797	9812	11828	14516	8607	10806	13005	15937	9207	11406	13605	16537	23221
10	1.75	11733	14775	17817	21873	12952	16270	19587	24011	13855	17172	20490	24913	63718
12	2	19260	24368	29476	36287	21071	26589	32106	39463	22412	27929	33447	40804	95113
14	2.25	28725	36481	44237	54579	31127	39426	47725	58791	32905	41204	49503	60568	135425
16	2.5	36459	46284	56111	69212	39650	50197	60745	74808	42012	52559	63107	77170	185768
18	2.5	51902	66083	80265	99174	55973	71074	86177	106313	58987	74088	89190	109326	185768
20	2.75	68926	87943	106961	132318	73858	93989	114122	140965	77508	97639	117772	144615	247257
24	3.25	110079	140749	171422	212317	117293	149592	181896	224964	122632	154931	187234	230303	408133
30	3.5	218218	279953	341694	424011	230020	294422	358830	444703	238755	303157	367565	453438	509748

Dimensions and Weights

ASME Class 150

Valve Size (inch)	Dimensions (mm)								Actuator Mounting	Weight (Kg)	
	LW	DF	B	C	D	Ø E	Ø F	Ø S	Flange Type ISO 5211	LW	DF
	A										
3	48	114	130	160	75	66	212	5/8"	F05	8	27
4	54	127	140	170	90	91	230	3/4"	F07	16	31
6	57	140	170	200	90	135	280	3/4"	F07	20	39
8	64	152	205	235	110	188	344	1"	F10	34	64
10	71	165	245	280	110	236	408	1"	F12	55	89
12	81	178	275	310	120	284	483	1-1/4"	F14	80	129
14	92	190	310	360	145	328	535	1-1/2"	F14	105	163
16	102	216	340	400	145	366	598	1-1/2"	F16	142	210
18	114	222	365	425	165	414	637	1-3/4"	F16	180	240
20	127	229	405	465	165	465	700	2"	F25	235	285
24	154	267	460	520	180	561	817	2-1/4"	F25	349	450
30	165	318	605	680	210	711	988	3"	F30	583	725

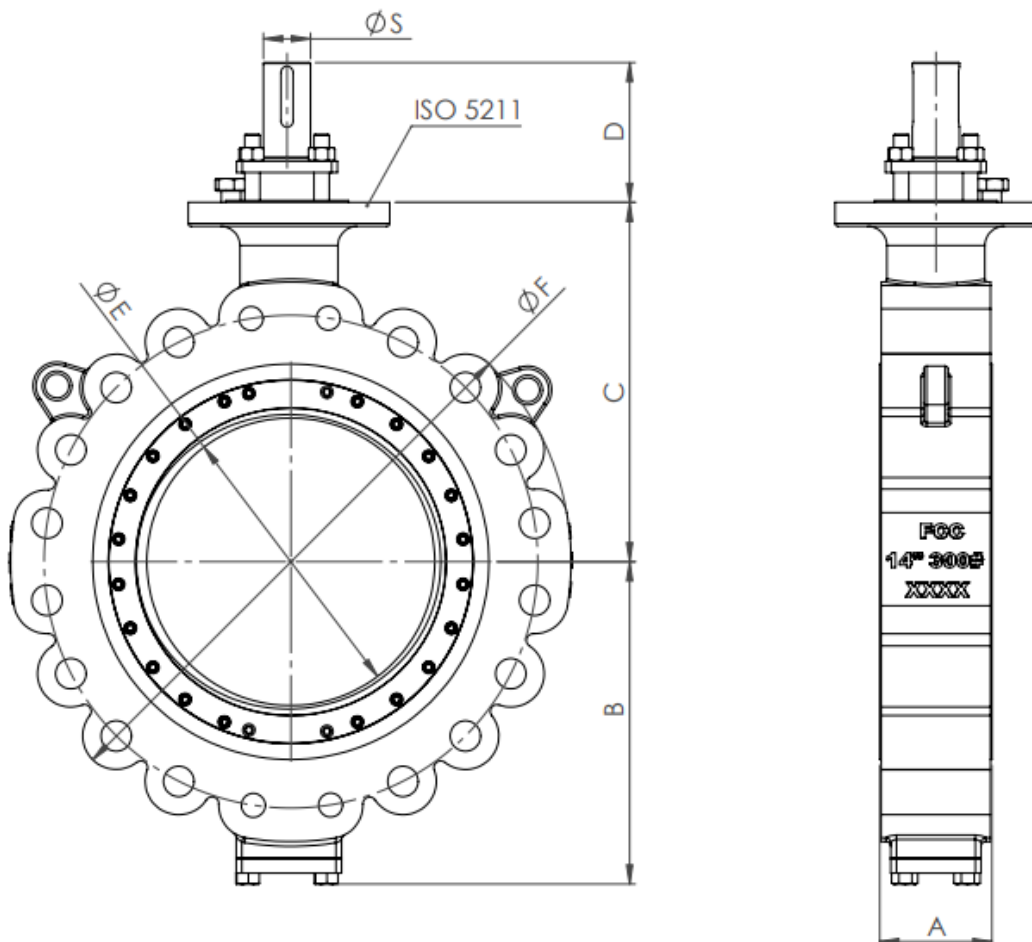

Series-20 High Performance Butterfly Valve

ASME Class 300

Valve Size (inch)	Dimensions (mm)								Actuator Mounting Flange Type ISO 5211	Weight (Kg)	
	LW	DF	B	C	D	Ø E	Ø F	Ø S		LW	DF
	A										
3	48	114	130	160	75	66	212	5/8"	F07	14	26
4	54	127	155	185	90	91	254	3/4"	F07	20	39
6	59	140	190	220	110	135	319	1"	F10	34	63
8	73	152	260	270	120	188	384	1-1/4"	F12	57	98
10	83	165	270	310	120	236	445	1-1/4"	F14	85	130
12	92	178	310	350	145	284	524	1-1/2"	F16	123	180
14	117	190	340	390	165	328	584	2"	F16	207	256
16	133	216	370	420	165	366	650	2"	F25	269	329
18	149	222	405	480	180	414	712	2-1/4"	F25	357	400
20	159	229	440	515	210	465	777	2-3/4"	F30	416	505
24	181	267	515	600	210	561	918	3"	F30	635	753
30	241	318	615	700	210	711	1096	3-1/2"	F35	1103	1125

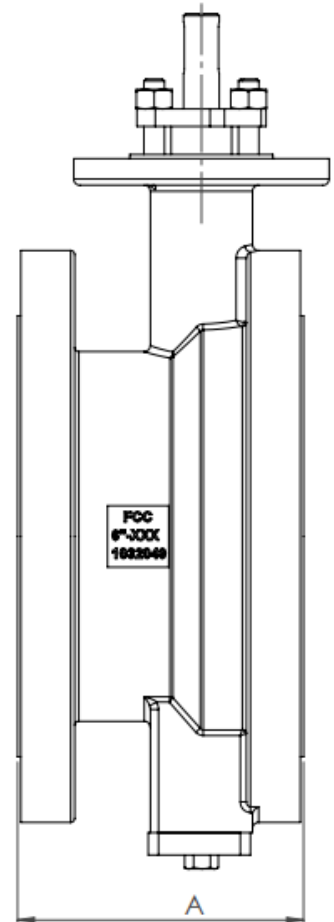
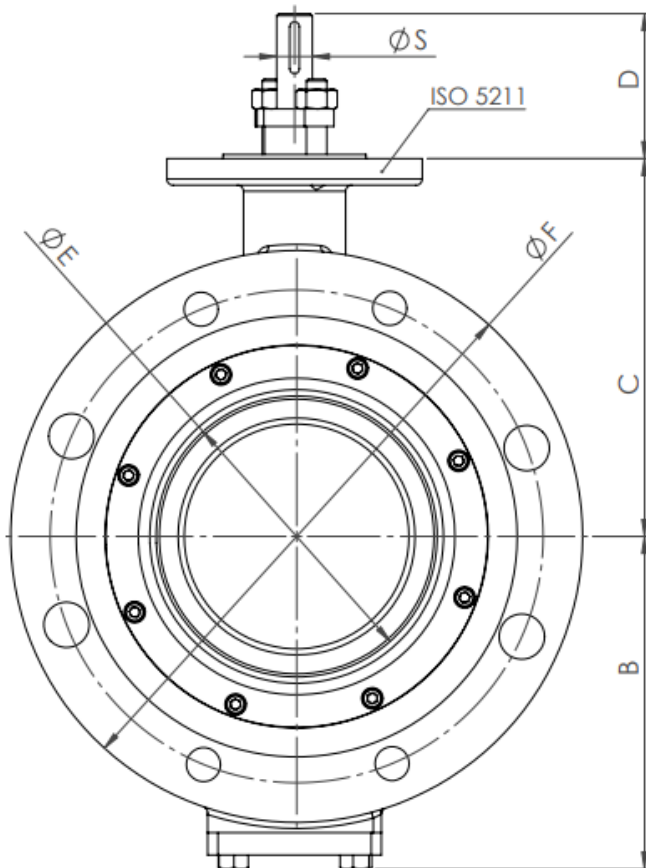

Series-20 High Performance Butterfly Valve

ASME Class 600

Valve Size (inch)	Dimensions (mm)								Actuator Mounting	Weight (Kg)	
	LW	DF	B	C	D	Ø E	Ø F	Ø S	Flange Type ISO 5211	LW	DF
	A										
3	54	180	130	165	75	66	210	5/8"	F10	15	30
4	64	190	165	210	90	91	275	3/4"	F10	28	52
6	78	210	215	250	110	135	355	1"	F12	58	101
8	102	230	255	290	120	188	422	1-1/4"	F14	99	173
10	117	250	305	350	165	236	510	1-3/4"	F16	178	270
12	140	270	335	380	165	284	560	2"	F25	223	310
14	155	290	355	410	180	328	605	2-1/4"	F25	280	370
16	178	310	420	500	200	366	688	2-1/2"	F30	425	550
18	200	330	440	520	200	414	745	2-1/2"	F30	515	660
20	216	350	470	550	210	465	815	2-3/4"	F35	652	780
24	232	390	535	620	210	561	942	3-1/4"	F35	880	1080
30	318	450	625	710	210	711	1132	3-1/2"	F40	1540	1750

End Connection Bolting Details (LW)

ASME Class 150

Valve Size (inch)	Drilled Holes					Tapped Holes				
	Stud Size	Length (in)	No of Studs	Nut Size	No of Nuts	Stud Size	Length (in)	No of Studs	Nut Size	No of Nuts
3	5/8- 11 UNC	6	4	5/8- 11 UNC	8	-	-	-	-	-
4	5/8- 11 UNC	6.25	8	5/8- 11 UNC	16	-	-	-	-	-
6	3/4- 10 UNC	6.75	8	3/4- 10 UNC	16	-	-	-	-	-
8	3/4- 10 UNC	7.25	8	3/4- 10 UNC	16	-	-	-	-	-
10	7/8- 9 UNC	8	12	7/8- 9 UNC	24	-	-	-	-	-
12	7/8- 9 UNC	8.5	12	7/8- 9 UNC	24	-	-	-	-	-
14	1-8 UN	9.5	12	1-8 UN	24	-	-	-	-	-
16	1-8 UN	10	16	1-8 UN	32	-	-	-	-	-
18	1-1/8- 8 UN	11	16	1-1/8- 8 UN	32	-	-	-	-	-
20	1-1/8- 8 UN	11.75	16	1-1/8- 8 UN	32	1-1/8- 8 UN	4.5	8	1-1/8- 8 UN	8
24	1-1/4- 8 UN	13.5	16	1-1/4- 8 UN	32	1-1/4- 8 UN	5	8	1-1/4- 8 UN	8
30	1-1/4- 8 UN	16.25	24	1-1/4- 8 UN	48	1-1/4- 8 UN	6.25	8	1-1/4- 8 UN	8

ASME Class 300

Valve Size (inch)	Drilled Holes					Tapped Holes				
	Stud Size	Length (in)	No of Studs	Nut Size	No of Nuts	Stud Size	Length (in)	No of Studs	Nut Size	No of Nuts
3	3/4- 10 UNC	6.5	8	3/4- 10 UNC	16	-	-	-	-	-
4	3/4- 10 UNC	7	8	3/4- 10 UNC	16	-	-	-	-	-
6	3/4- 10 UNC	7.75	12	3/4-10 UNC	24	-	-	-	-	-
8	7/8- 9 UNC	9	12	7/8- 9 UNC	24	-	-	-	-	-
10	1-8 UN	10	12	1-8 UN	24	1-8 UN	4.5	8	1-8 UN	8
12	1-1/8- 8 UN	11	16	1-1/8- 8 UN	32	1-1/8-8 UN	4.75	8	1-1/8- 8 UN	8
14	1-1/8- 8 UN	12.25	16	1-1/8- 8 UN	32	1-1/8-8 UN	5	8	1-1/8- 8 UN	8
16	1-1/4- 8 UN	13.25	16	1-1/4- 8 UN	32	1-1/4- 8 UN	5.25	8	1-1/4- 8 UN	8
18	1-1/4- 8 UN	14.25	20	1-1/4- 8 UN	40	1-1/4- 8 UN	5.5	8	1-1/4- 8 UN	8
20	1-1/4- 8 UN	15	20	1-1/4- 8 UN	40	1-1/4- 8 UN	5.75	8	1-1/4- 8 UN	8
24	1-1/2- 8 UN	16.75	20	1-1/2- 8 UN	40	1-1/2- 8 UN	6.5	8	1-1/2- 8 UN	8
30	1-3/4- 8 UN	21.75	24	1-3/4- 8 UN	48	1-3/4- 8 UN	8	8	1-3/4- 8 UN	8

Series-20 High Performance Butterfly Valve

ASME Class 600

Valve Size (inch)	Drilled Holes					Tapped Holes				
	Stud Size	Length (in)	No of Studs	Nut Size	No of Nuts	Stud Size	Length (in)	No of Studs	Nut Size	No of Nuts
3	3/4- 10 UNC	7.25	8	3/4- 10 UNC	16	-	-	-	-	-
4	7/8- 9 UNC	8.5	8	7/8- 9 UNC	16	-	-	-	-	-
6	1-8 UN	10	12	1-8 UN	24	-	-	-	-	-
8	1-1/8- 8 UN	11.75	12	1-1/8- 8UN	24	-	-	-	-	-
10	1-1/4- 8 UN	13.25	12	1-1/4- 8 UN	24	1-1/4-8 UN	5.75	8	1-1/4- 8 UN	8
12	1-1/4-8 UN	14.5	16	1-1/4- 8 UN	32	1-1/4-8 UN	5.75	8	1-1/4- 8 UN	8
14	1-3/8- 8 UN	15.5	16	1-3/8- 8 UN	32	1-3/8-8 UN	6.25	8	1-3/8- 8 UN	8
16	1-1/2- 8 UN	17.25	16	1-1/2- 8 UN	32	1-1/2- 8 UN	6.75	8	1-1/2- 8 UN	8
18	1-5/8- 8 UN	18.75	16	1-5/8- 8 UN	32	1-5/8- 8 UN	7.25	8	1-5/8- 8 UN	8
20	1-5/8- 8 UN	20	20	1-5/8- 8 UN	40	1-5/8- 8 UN	7.5	8	1-5/8- 8 UN	8
24	1-7/8- 8 UN	22.25	20	1-7/8- 8 UN	40	1-7/8- 8 UN	8.5	8	1-7/8- 8 UN	8
30	2- 8 UN	27.25	24	2- 8 UN	48	2- 8 UN	9.5	8	2- 8 UN	8

End Connection Bolting Details (DF)

ASME Class 150

Valve Size (inch)	Drilled Holes					Tapped Holes				
	Stud Size	Length (in)	No of Studs	Nut Size	No of Nuts	Stud Size	Length (in)	No of Studs	Nut Size	No of Nuts
3	5/8- 11 UNC	4	8	5/8- 11 UNC	16	-	-	-	-	-
4	5/8- 11 UNC	4	8	5/8- 11 UNC	16	5/8-11 UNC	2.75	8	5/8- 11 UNC	8
6	3/4- 10 UNC	4.25	8	3/4- 10 UNC	16	3/4-10 UNC	3	8	3/4- 10 UNC	8
8	3/4- 10 UNC	4.5	8	3/4- 10 UNC	16	3/4-10 UNC	3.25	8	3/4- 10 UNC	8
10	7/8- 9 UNC	5	16	7/8- 9 UNC	32	7/8- 9 UNC	3.5	8	7/8- 9 UNC	8
12	7/8- 9 UNC	5	16	7/8- 9 UNC	32	7/8-9 UNC	3.5	8	7/8- 9 UNC	8
14	1-8 UN	5.75	16	1-8 UN	32	1-8 UN	4	8	1-8 UN	8
16	1-8 UN	5.75	24	1-8 UN	48	1-8 UN	4	8	1-8 UN	8
18	1-1/8- 8 UN	6.25	24	1-1/8- 8 UN	48	1-1/8-8 UN	4.5	8	1-1/8- 8 UN	8
20	1-1/8- 8 UN	6.25	32	1-1/8- 8 UN	64	1-1/8- 8 UN	4.5	8	1-1/8- 8 UN	8
24	1-1/4- 8 UN	7.25	32	1-1/4- 8 UN	64	1-1/4- 8 UN	5	8	1-1/4- 8 UN	8
30	1-1/4- 8 UN	9.75	48	1-1/4- 8 UN	96	1-1/4- 8 UN	6.25	8	1-1/4- 8 UN	8

Series-20 High Performance Butterfly Valve

ASME Class 300

Valve Size (inch)	Drilled Holes					Tapped Holes				
	Stud Size	Length (in)	No of Studs	Nut Size	No of Nuts	Stud Size	Length (in)	No of Studs	Nut Size	No of Nuts
3	3/4- 10 UNC	4.5	8	3/4- 10 UNC	16	3/4-10 UNC	3.25	8	3/4- 10 UNC	8
4	3/4- 10 UNC	4.75	8	3/4- 10 UNC	16	3/4-10 UNC	3.25	8	3/4- 10 UNC	8
6	3/4- 10 UNC	5.25	16	3/4-10 UNC	32	3/4-10 UNC	3.5	8	3/4- 10 UNC	8
8	7/8- 9 UNC	5.75	16	7/8- 9 UNC	32	7/8- 9 UNC	4	8	7/8- 9 UNC	8
10	1-8 UN	6.75	24	1-8 UN	48	1-8 UN	4.5	8	1-8 UN	8
12	1-1/8- 8 UN	7.25	24	1-1/8- 8 UN	48	1-1/8-8 UN	4.75	8	1-1/8- 8 UN	8
14	1-1/8- 8 UN	7.5	32	1-1/8- 8 UN	64	1-1/8-8 UN	5	8	1-1/8- 8 UN	8
16	1-1/4- 8 UN	8	32	1-1/4- 8 UN	64	1-1/4- 8 UN	5.25	8	1-1/4- 8 UN	8
18	1-1/4- 8 UN	8.25	40	1-1/4- 8 UN	80	1-1/4- 8 UN	5.5	8	1-1/4- 8 UN	8
20	1-1/4- 8 UN	8.5	40	1-1/4- 8 UN	80	1-1/4- 8 UN	5.75	8	1-1/4- 8 UN	8
24	1-1/2- 8 UN	9.5	40	1-1/2- 8 UN	80	1-1/2- 8 UN	6.5	8	1-1/2- 8 UN	8
30	1-3/4- 8 UN	12.25	48	1-3/4- 8 UN	96	1-3/4- 8 UN	8	8	1-3/4- 8 UN	8

ASME Class 600

Valve Size (inch)	Drilled Holes					Tapped Holes				
	Stud Size	Length (in)	No of Studs	Nut Size	No of Nuts	Stud Size	Length (in)	No of Studs	Nut Size	No of Nuts
3	3/4- 10 UNC	5	8	3/4- 10 UNC	16	3/4-10 UNC	3.25	8	3/4- 10 UNC	8
4	7/8- 9 UNC	5.75	8	7/8- 9 UNC	16	7/8- 9 UNC	4	8	7/8- 9 UNC	8
6	1-8 UN	6.75	16	1-8 UN	32	1-8 UN	4.5	8	1-8 UN	8
8	1-1/8- 8 UN	7.75	16	1-1/8- 8UN	32	1-1/8-8 UN	5	8	1-1/4- 8 UN	8
10	1-1/4- 8 UN	8.5	24	1-1/4- 8 UN	48	1-1/4-8 UN	5.75	8	1-1/4- 8 UN	8
12	1-1/4-8 UN	8.75	32	1-1/4- 8 UN	64	1-1/4-8 UN	5.75	8	1-1/4- 8 UN	8
14	1-3/8- 8 UN	9.25	32	1-3/8- 8 UN	64	1-3/8-8 UN	6.25	8	1-3/8- 8 UN	8
16	1-1/2- 8 UN	10	32	1-1/2- 8 UN	64	1-1/2- 8 UN	6.75	8	1-1/2- 8 UN	8
18	1-5/8- 8 UN	10.75	32	1-5/8- 8 UN	64	1-5/8- 8 UN	7.25	8	1-5/8- 8 UN	8
20	1-5/8- 8 UN	11.5	40	1-5/8- 8 UN	80	1-5/8- 8 UN	7.5	8	1-5/8- 8 UN	8
24	1-7/8- 8 UN	13	40	1-7/8- 8 UN	80	1-7/8- 8 UN	8.5	8	1-7/8- 8 UN	8
30	2- 8 UN	14.5	48	2- 8 UN	96	2- 8 UN	9.5	8	2- 8 UN	8



Factory Address

Flow Control Commune
9 Multi Industrial Estate, Gerugambakkam
Chennai 600122, India

Contact details

Phone: +91 44 3500 1197
Email: info@fccommune.com
Website: www.fccommune.com